

Mirplay[®]
school

#Neverstopplaying
#Neverstoplearning





The school that I want

By listening to what the school you imagine is like,
we can offer you the furniture you need.

A school with comfortable, versatile furniture that supports
the different educational dynamics that take place in it and
that absorbs the use and pace of the students. Beautiful, solid
and mobile furniture aligned with today's pedagogies.

We are your partner in furniture to create the school you want.

Escuchando cómo es la escuela que imaginas
podemos ofrecerte los muebles que necesitas.

Una escuela con muebles confortables, versátiles, que dan apoyo
a las diferentes dinámicas educativas que en ella se desarrollan
y absorben el uso y el ritmo de los alumnos. Muebles bonitos,
sólidos y móviles alineados con las pedagogías de hoy.

Somos tu partner de mobiliario para crear la escuela que tú quieres.

Who are we?

We are a team with a family tradition and an international spirit that helps schools, high schools and universities around the world to improve their learning spaces.

Providing solutions that create versatile spaces, in which the student is the centre and learning expands, is what drives us.

Somos un equipo con ADN familiar y espíritu internacional que ayuda a las escuelas, institutos y universidades del mundo a mejorar sus espacios de aprendizaje.

Dar soluciones que creen espacios versátiles, en los que el alumno es el centro y el aprendizaje se expanda, es nuestro motor.



CLASSROOM DESIGN
DISEÑO DE AULAS



FAST DELIVERY
ENTREGA RÁPIDA



AFFORDABLE PRICES
PRECIOS ASEQUIBLES



INNOVATIVE PROPOSALS
PROPUESTAS INNOVADORAS



QUALITY MATERIALS
MATERIALES DE CALIDAD



CERTIFICATIONS
CERTIFICACIONES



PERSONALIZED ATTENTION
ATENCIÓN PERSONALIZADA



Colour for learning

The new line of furniture for learning features a colour palette inspired by nature. Colours of the sea, land and sky harmonize the design and offer a calm and comfortable beauty that responds to an expanding trend in the school sector.

La nueva línea de muebles para el aprendizaje presenta una paleta de colores inspirada en la naturaleza. Cromatismos del mar, la tierra y el cielo armonizan el diseño y ofrecen una belleza calmada y confortable que da respuesta a una tendencia en expansión del sector escolar.

LIGHT GREY

A neutral and balanced colour. Light grey is associated with conservative and sophisticated meanings.

Un color neutro y equilibrado. El gris claro se asocia a opciones conservadoras y sofisticadas.



TERRACOTA

It's not a single colour, but a family of colours that resemble fired clay. It means "fired earth" and the component colours are typically orange and brown.

No se trata de un solo color, sino de una familia de colores que recuerdan la arcilla cocida. Significa "tierra cocida" y los colores que la componen son habitualmente naranja y marrón.

OCRE

Possibly one of the oldest colours and a symbol of life. Some societies quite often associate it with life.

Posiblemente uno de los colores más antiguos y un símbolo vital. Algunas sociedades lo asocian habitualmente con la vida.



MINT

A freshening and welcoming hue associated with summer and water activities because of its similarity to sea shades and pools. It represents tranquillity, balance and calm.

Tonalidad refrescante y acogedora asociada a las actividades de verano y acuáticas por su similitud con las sombras del mar y las piscinas. Representa tranquilidad, equilibrio y calma.

NAVY

Chromatic harmony is the equilibrium that one obtains when the right colours are combined. It is consonance, it is calm, it is a piano perfectly in tune.

La armonía cromática es el equilibrio que se obtiene cuando se combinan los colores adecuados. Es consonancia, es calma, es un piano perfectamente afinado.

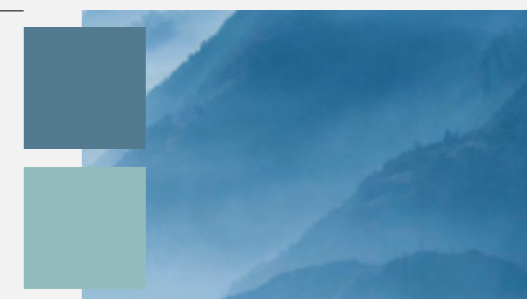

CHARCOAL

It has a great expressive value: highlights the forms, making them more elegant and sophisticated. It's the colour that combines in perfect harmony with all the others.

Tiene un gran valor expresivo: resalta las formas, haciéndolas más elegantes y sofisticadas. Es el color que combina en perfecta armonía con todos los demás.

Index

Learning spaces

10

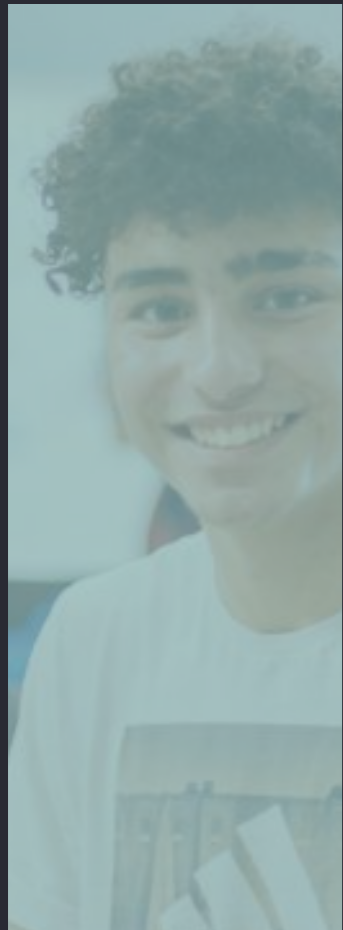

S.T.E.A.M.

32

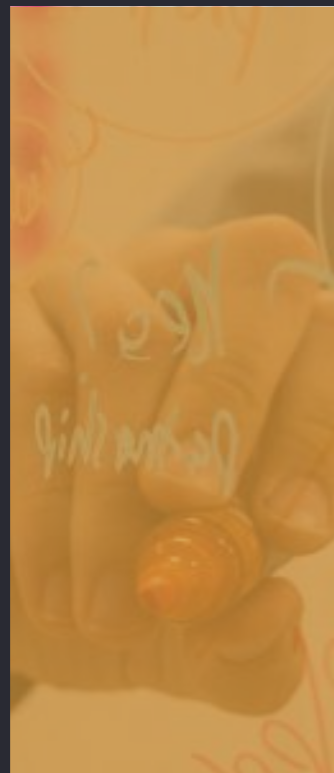

Technology

40

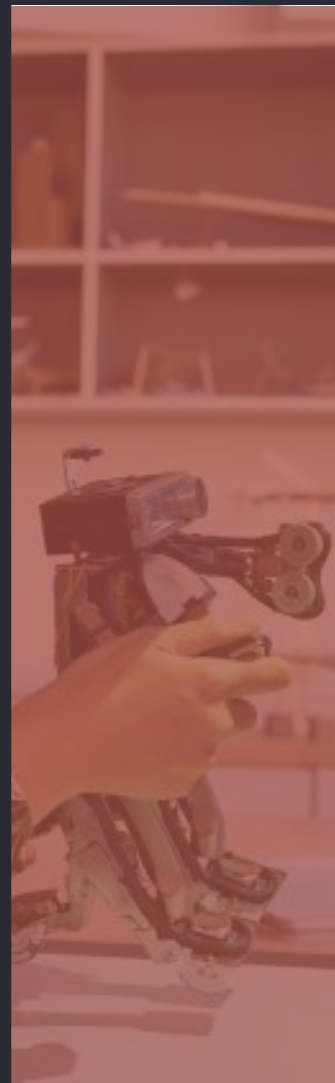

Teacher's space

48

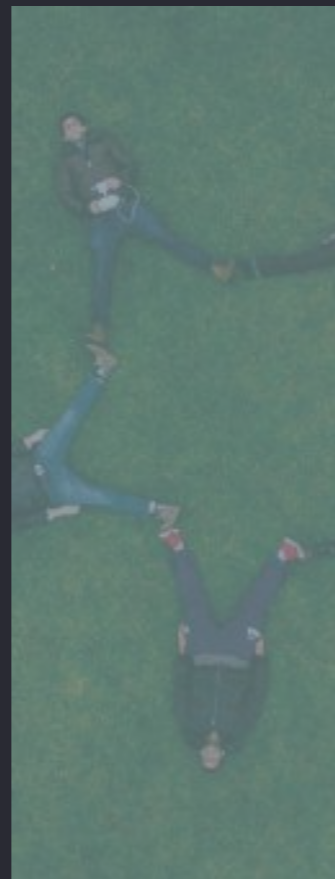

Multipurpose spaces

56



Canteen

66

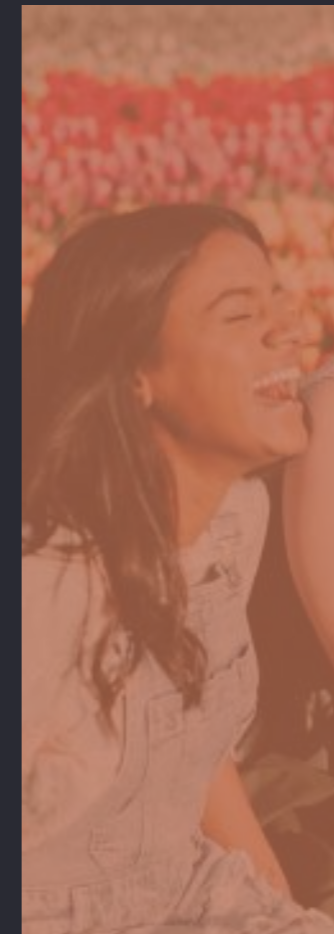

Early ages

74

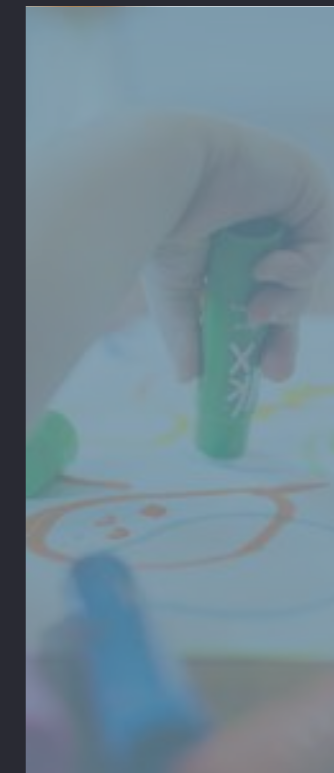

CHAIRS
92



SOFT SEATING
110



TABLES
118

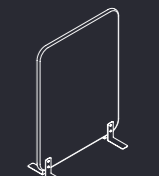

ACOUSTIC
148



CABINETS
156

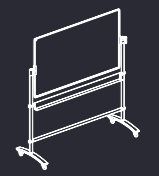

COMPLEMENTS
178



Learning spaces

Discovering, organizing and transforming our world is exciting, stimulating and a daily challenge we can make a reality in any space.

How can we create diverse learning spaces?

Descubrir, organizar y transformar el mundo que nos rodea es estimulante, apasionante y un desafío diario que podemos hacer que ocurra en cualquier espacio.

¿Cómo crear espacios de aprendizaje diversos?



LEARNING SPACES

The joy of growing and expanding

The school is that friendly and safe space where understanding, creativity and feelings allow to discover both the world and oneself.

La escuela es el espacio amigable y seguro en el que la comprensión, la creatividad y el sentir permiten descubrir tanto el mundo como a uno mismo.



Dividing is adding.





Separating areas within the same space is easy with panels that also provide acoustic comfort. The learning environment has a deep impact on the educational results of all students. Shall we make the most of every square meter?

Separar zonas en un mismo espacio es fácil con los paneles que además aportan confort acústico. El entorno de aprendizaje tiene un efecto profundo en los resultados educativos de todos los alumnos, ¿le sacamos partido a cada metro cuadrado?

54 m² 30



HEXA

The HEXA table is the paradigm of versatility and storage optimization.

La mesa HEXA es el paradigma de la versatilidad y la optimización en su almacenaje



SAMOS

SAMOS acoustic panels divide spaces and dampen sound, making communication easier.

Los paneles acústicos SAMOS, separan espacios y amortiguan el sonido facilitando la comunicación.



MIA LIFT

Ergonomic MIA chairs favour the natural movement of the body. With padded seat option for extra comfort.

Las sillas ergonómicas MIA facilitan el movimiento natural de cuerpo. Con opción de tapizado para mayor confort.

Learning in motion.





The learning experience needs guidance, but also freedom. Freedom of movement to create and dismantle work groups with versatile tables. Spaces bringing about learning with order and good acoustics to facilitate communication and comfort.

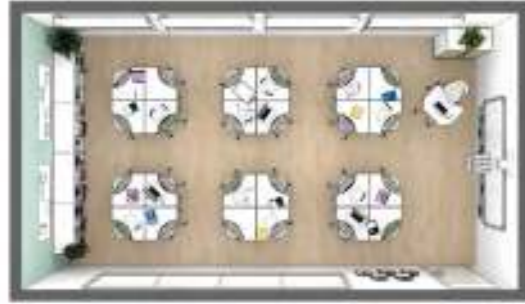

La experiencia del aprendizaje necesita guía, pero también libertad. Libertad de movimiento para agruparse y desagruparse por equipos de trabajo con mesas versátiles. Espacios que sean catalizadores del conocimiento con orden, buena acústica para facilitar la comunicación, comodidad y confort.



 45 m²  24



The MINI LILY individual whiteboard and its storage system promote order and debate in the classroom.

MINI LILY



La pizarra individual MINI LILY y su sistema de almacenaje facilitan el debate y el orden en el aula

The MOON table, adjustable in height, provides teachers with the position within the group that they need at all times.

MOON



La mesa MOON, regulable en altura, proporciona al profesorado la posición dentro del grupo que necesita en cada momento.

*Small changes,
big improvements.*

360°
view



Sometimes, it all comes down to having the ideal chairs and desks to improve concentration, order and comfort, and just letting space and natural light do the rest.

A veces solo es necesario contar con los pupitres y las sillas idóneas para ganar en concentración, orden y confort y dejar que el espacio y la luz natural hagan el resto.



45 m² 24



RECTANGLE TEACHER

The classical teacher's desk with drawer and modesty panel is called RECTANGLE TEACHER.

La clásica mesa para profesorado con cajón y faldón se llama RECTANGLE TEACHER.



MIA CANTILEVER

The MIA CANTILEVER chair helps to optimize cleanliness and order in classrooms.

La silla MIA CANTILEVER ayuda a optimizar la limpieza y el orden en las aulas.



*Welcome to the
superclassroom.*

360°
view







In multi-purpose spaces with multiple dynamics, the Teaching-how-to-Learn paradigm shift shines. In these areas, the organization of space, time and materials is key to facilitating synergies.

En los espacios polivalentes de múltiples dinámicas es donde brilla el cambio de paradigma de enseñar a aprender. En ellos la organización del espacio, del tiempo y de los materiales es clave para facilitar sinergias.



 150 m²  60



MIA TABLE

MIA TABLE chairs with folding table and lower storage tray to easily form and dismantle groups.

Sillas con pala y almacenaje MIA TABLE para agruparse y desagruparse fácilmente.



MIA STORE

Large work tables and MIA STORE chairs with a storage tray so that dynamism in the super classroom does not mean clutter.

Mesas amplias de trabajo y sillas MIA STORE con bandeja para almacenaje para que el dinamismo en la súperaula no altere su orden.





Marga Tubau

Sales Manager

What can make neurons dance?

A strategically placed sofa. A panel that turns into a mobile whiteboard. Let the desire to learn, share ideas and contrast them find their space in any corner.

¿Qué puede hacer que las neuronas bailen?

Un sofá estratégicamente ubicado. Un panel que es una pizarra móvil. Hagamos que las ganas de aprender, compartir ideas y contrastarlas encuentren su espacio en cualquier rincón.



A passage area or a corner of 3m² allows a one-on-one meeting.

Una zona de paso o un rincón de 3m² da lugar a una reunión de tú a tú

The combination of grades in different sizes creates a facilitating space for meetings and discussions.

La combinación de gradas de diferentes dimensiones crea el espacio facilitador para el fórum o el debate



Tips for corners

Create a discussion area in a classroom: it just takes a sofa, a whiteboard and an acoustic divider.

Crear una zona de debate en un aula: este rincón solo necesita un sofá, una pizarra y divisor acústico





S.T.E.A.M.

*Science. Technology.
Engineering. [Arts]. Maths.*

Transversal and multidisciplinary learning enhances the capacity for research, exploration, problem solving and curiosity. Learn by combining various fields of knowledge in the same space.

How to create STEAM learning classrooms?

El aprendizaje transversal y multidisciplinar potencia la capacidad de investigación, exploración, resolución de problemas y la curiosidad. Aprender conjugando diversos ámbitos de conocimiento en un mismo espacio.

¿Cómo crear aulas de aprendizaje STEAM?



S.T.E.A.M.

Classrooms with space for everything

The desire to learn is the engine for knowledge and an endless source of personal satisfaction. Stimulating spaces have to be created.

A classroom where the teacher can play different roles and students can perform different activities at the same time?

Las ganas de saber son el motor del conocimiento y una inagotable fuente de satisfacción personal. Hay que crear espacios que las estimulen.

¿Un aula donde el docente puede ejercer diferentes roles y los alumnos desarrollar distintas actividades a la vez?

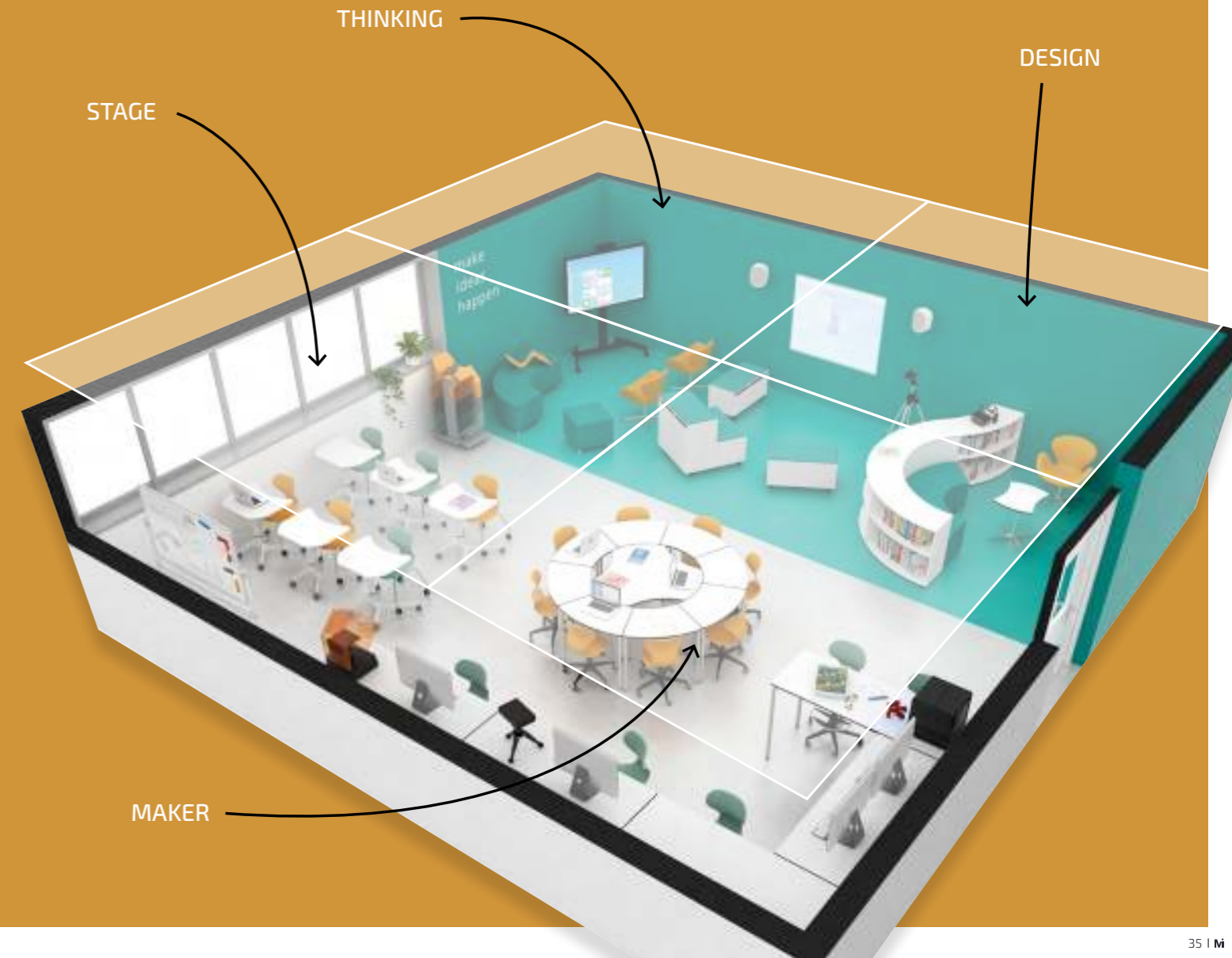

*The same stage
multiple spaces*

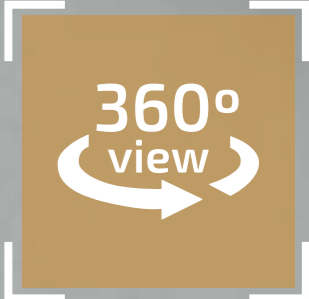



A multidirectional space with zones to carry out different activities related to the same project not only optimizes time and space, but it also fosters concentration and cooperative work.

The goal is to create spaces that are allied with knowledge. Shall we do it?

Un espacio multidireccional con diferentes zonas para diversas actividades relacionadas con la ejecución de un mismo proyecto no solo optimiza tiempo y espacio, también estimula la concentración y el trabajo cooperativo.

El objetivo es crear ambientes que se alíen con el conocimiento. ¿Lo hacemos?

 87 m²

 40



MOVE

MINI MOVE

MOVE and MINI MOVE grades create a forum area for expositions and debates.

Las gradas MOVE y MINI MOVE crean una zona forum para la exposición y el debate.



OCTA

TRISIX

OCTA and TRISIX tables allow you to quickly create work groups, providing a design zone when needed.

Las mesas OCTA y TRISIX permiten crear ágilmente grupos de trabajo facilitando una zona design cuando se necesita.



Tech —nology

The technological ecosystem is part of the life of 21st century students. They are protagonists and will be the creators of the technology we use on a daily basis. Programming, ICT and robotics have their own space.

How to foster technological learning?

El ecosistema tecnológico forma parte de la vida de los estudiantes del siglo XXI. Ellos son protagonistas y serán los creadores de la tecnología que utilizamos en el día a día. La programación, las TIC y la robótica tienen su propio espacio.

¿Cómo facilitar el aprendizaje tecnológico?

TECHNOLOGY

Technology is the way, not the message.

By programming, students improve their ICT knowledge and they also learn to work in groups, negotiate, be assertive, manage frustration, present ideas, gain efficiency, security, analytical skills and a large number of necessary abilities in the current and future work environment.

Programando los alumnos mejoran en conocimientos TIC, pero también aprenden a trabajar en grupo, negociar, ser asertivos, gestionar la frustración, presentar ideas, ganar en eficiencia, seguridad y capacidad de análisis y un gran número de habilidades necesarias en panorama laboral del presente y del futuro.



Ideas lab.

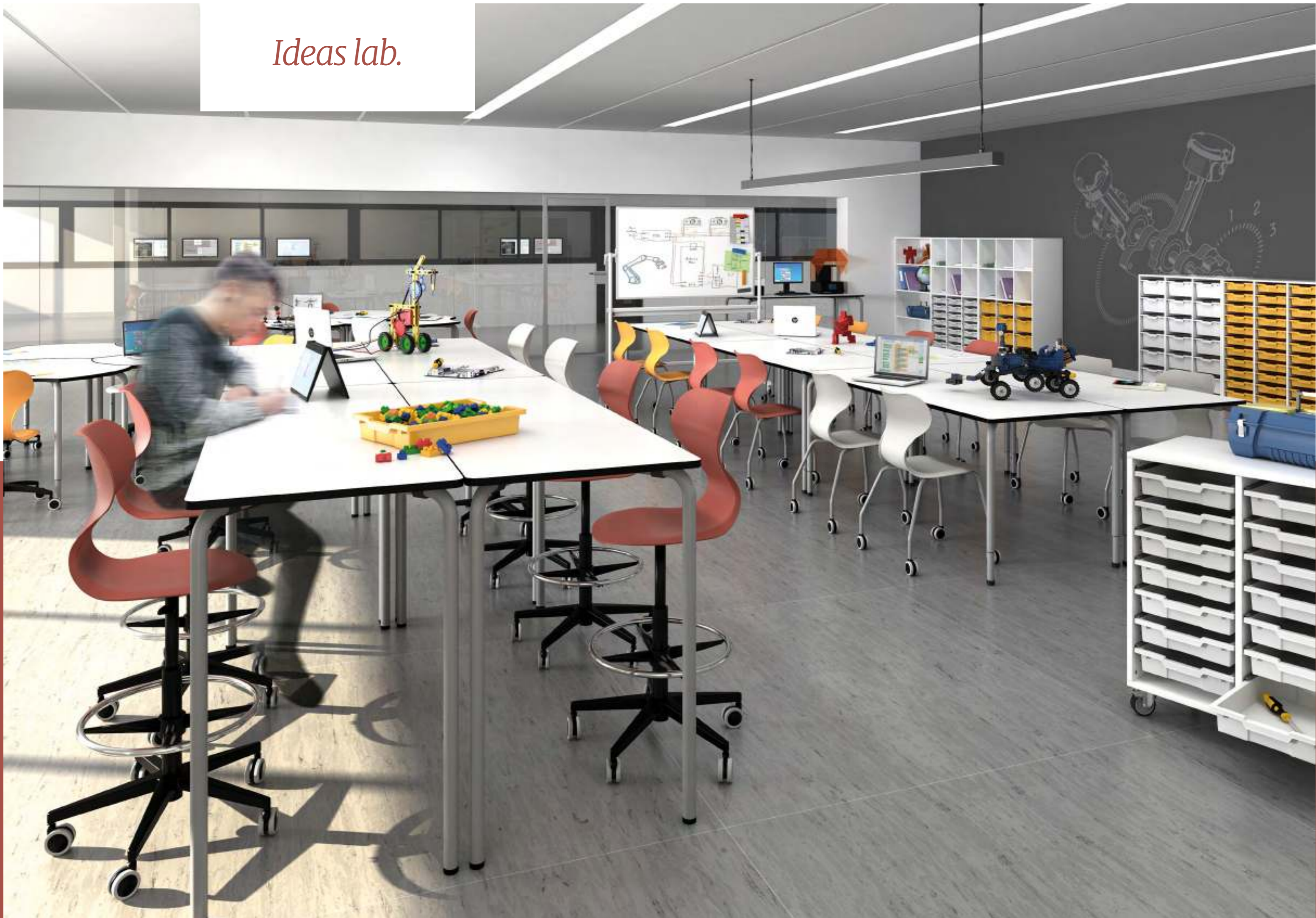



Design contributes to making the educational experience more effective, pleasant and fulfilling in the technology classroom.

Freedom of movement is key here for an agile manipulation of the object of study and the possibility of grouping in small work teams. Whiteboards and mobile auxiliary furniture allow the sharing of ideas and materials

El diseño contribuye a hacer la experiencia educativa más eficaz, placentera y plena en el aula tecnológica.

Aquí la libertad de movimiento para la ágil manipulación del objeto de estudio y la opción de agruparse en equipos de trabajo reducidos es clave. Las pizarras y los muebles auxiliares móviles permiten compartir ideas y materiales.

150 m² 45



MIA STOOL



RECTANGLE PLUS



TRISIX

High and spacious tables, ideal for teamwork and ergonomic stools. RECTANGLE table and MIA stools.

Mesas altas y espaciosas, idóneas para trabajar en equipo y taburetes ergonómicos. Mesa RECTANGLE PLUS y taburete MIA STOOL

Versatile and easy to fit tables to form and dismantle work teams.

Mesas versátiles y fácilmente almacenables para agrupar y desagrupar equipos de trabajo.



Teacher's space

The engine and heart of the school are the teaching team. Teachers need a space to rest, relax and at the same time work as a team, talk and continue promoting education today and tomorrow.

How do you imagine the staff room?

El motor y corazón de la escuela son el equipo docente. El profesorado necesita un espacio para descansar, relajarse y a la vez trabajar en equipo, conversar y seguir impulsando la educación de hoy y mañana.

¿Cómo imaginas la sala de profesores?

TEACHER'S SPACE

Creators of learning experiences

If the teacher is the designer of the learning experience, the educational space is the setting that inspires it.

Si el docente es el diseñador de la experiencia de aprendizaje, el espacio educativo es el escenario que la inspira.



A small oasis.

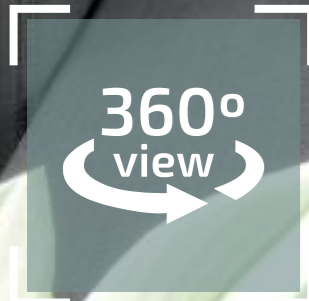
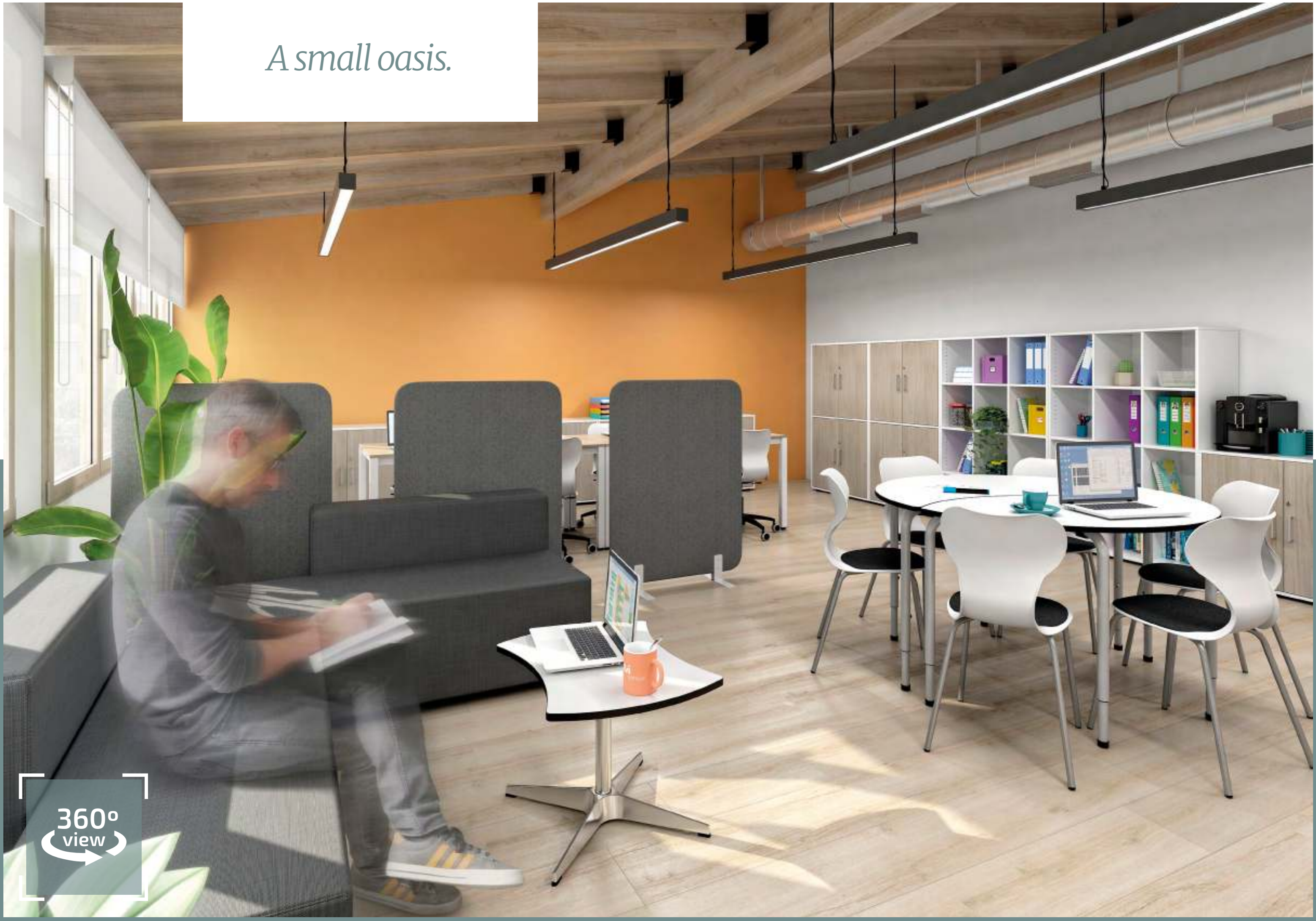



The place for reflection, assessment, content preparation and rest. The space for interaction between co-workers and meetings between tutors and students.

El lugar para la reflexión, la evaluación, la preparación de contenidos y el descanso. El espacio para la interacción entre compañeros de trabajo y las reuniones entre tutores y alumno.

50 m² 22



SAMOS

SAMOS dividers separate and isolate acoustically.

Los divisores SAMOS separan y aíslan acústicamente



YANG

YANG tables to close the circle.

Mesas YANG para una mesa redonda



Multi — purpose spaces

Spaces are constantly evolving and many of them are transformed and inhabited in multiple ways. The diversity of activities gives way to the versatility, movement and multiple uses of furniture.

How to create multifunctional spaces?

Los espacios están en constante evolución y muchos de ellos se transforman y se habitan de múltiples formas. La diversidad de actividades abre paso a la versatilidad, el movimiento y los múltiples usos del mobiliario.

¿Cómo crear espacios multifuncionales?

MULTIPURPOSE SPACES

Libraries shout: **Come!**

Libraries go from being a place where people just do research to become a place to go to feel more productive or to be close to friends and colleagues.

They become interdisciplinary, inclusive and inspiring learning spaces.

Las bibliotecas pasan de ser un lugar al que las personas van solo para investigar a un lugar que eligen visitar porque se sienten más productivos o quieren estar cerca de amigos y colegas.

Se convierten en espacios de aprendizaje interdisciplinarios, inclusivos e inspiradores.





Wellness feeling.





Libraries are at the intersection of academic, social and emotional needs. They become a meeting place where students can grow in many aspects.

Las bibliotecas se encuentran en la intersección de las necesidades académicas, sociales y emocionales. Se convierten en lugar de reunión donde los estudiantes pueden desarrollarse en múltiples dimensiones.

 220 m²  75



Areas to sit and read as you would at home. Set of armchair and low table.

CHARLOTTE

Zonas para sentarse a leer como lo harías en casa. Conjunto de butacas y mesa baja.

LOUISE

Furniture with organic shapes that allows dividing spaces and create a comfort zone with sofas.

MARIE

Mobiliario de formas orgánicas que permite delimitar espacios y crear zona de confort con sofás.





Joan Jalencas

Sales Manager

Get together, meet, concentrate, explain, experiment, share, listen actively, etc., in different areas within the same educational, with versatile and mobile furniture, as well equipped as the mind is when learning.

Agruparse, reunirse, concentrarse, explicarse, experimentar, compartir, escuchar activamente... en un mismo espacio educativo con zonas diferenciadas, bien equipadas con mobiliario versátil y móvil. Tanto como lo es la mente cuando aprende.



The MARIE curved cabinet surrounds a space that, together with the ANGLE sofa, invites to meet in small groups to debate.

El armario en curva MARIE recoge un espacio que con el sofá ANGLE invita a reunirse en pequeños grupos para debatir.

The double-height MARIE curved cabinet creates an interior space that enables a quiet work area with a large table.

El armario en curva MARIE en doble altura crea un espacio interior que habilita una zona de trabajo tranquila con una amplia mesa.



Tips for corners

The CHARLOTTE armchair, with its wraparound seat, leads to internalisation, calm and meditation.

La butaca CHARLOTTE, asiento envolvente, conduce a la interiorización, la calma y la meditación.





Canteen

Educate, socialize and rest in the canteen to nurture students and teachers.

Each age has specific needs and creating a pleasant and calm atmosphere around the table is the starting point.

How to create canteens that nurture learning?

Educar, socializar y descansar desde el comedor para nutrir a alumnos y profesorado.

Cada edad tiene unas necesidades concretas y crear un entorno agradable y tranquilo alrededor de la mesa es el punto de partida.

¿Cómo crear cantinas que alimenten el aprendizaje?

CANTEEN

Much more than eating

Eating is a basic need. So are socializing, enjoying, savouring, learning, sharing, relaxing and nourishing oneself internally and externally.

Alimentarse es una necesidad. Socializar, disfrutar, saborear, aprender, compartir, descansar y nutrirse por dentro y por fuera, también.



Meeting point.

360°
view





As at home, where kitchen becomes the nerve centre where life happens, we can turn the canteen into something more than just a place to eat. The wood finishes, the organic colors and the design aiming to offer comfort are the key.

Como ocurre en un hogar, donde la cocina acaba siendo el punto neurálgico donde se desarrolla la vida, podemos conseguir que la cantina se habite para mucho más que para solo comer. Los acabados de madera, los colores orgánicos y el diseño pensado para ofrecer confort y comodidad, son la clave.

 108 m²  48



LUCA

The LUCA chair is stackable, easy to clean and maintain.

La silla LUCA es apilable, fácil de mantener y limpiar.



IRENE

The IRENE cabinet with its wooden doors brings warmth to the canteen and helps keep the space tidy and clean.

El armario IRENE con sus puertas de madera aporta calidez al comedor y ayuda a mantener el espacio ordenado y limpio.



Early ages

Feeling safe playing, experimenting calmly, surrounded by beauty and order. Spaces where the little ones are the protagonists offer comfort and security to imagine, create and grow freely.

How to create learning spaces that promote calm?

Sentirse seguro jugando, experimentar con calma, rodeado de belleza y orden. Los espacios donde los más pequeños son los protagonistas ofrecen confort y seguridad para imaginar, crear y crecer libremente.

¿Cómo crear espacios de aprendizaje que promuevan la calma?

EARLY AGES

Sensory experimentation

A classroom with different corners where symbolic play can be developed and sensory stimulation favored by manipulating different objects that are the center of interest for the little ones.

Un aula con diferentes rincones donde desarrollar el juego simbólico y favorecer la estimulación sensorial con la manipulación de diferentes objetos que son centro de interés de los más pequeños.





The living classroom.





Classrooms where different educational dynamics coexist simultaneously, where the little ones move, group and ungroup to experiment, rest, play.

Aulas en las que conviven simultáneamente diferentes dinámicas educativas, donde los más pequeños se mueven, agrupan y desagrupan para experimentar, descansar, jugar.

 100 m²  25



TEO

The wood in tables (TEO) and chairs (ZOE) brings warmth and comfort to the classroom.

La madera en mesas (TEO) y sillas (ZOE) aporta calidez y confort al aula.

ZOE



HEDY

The HEDY cabinet on castors allows you to comfortably and dynamically separate spaces.

El armario con ruedas HEDY permite separar espacios cómodamente y de forma dinámica.



MINIFLOOP

The MINIFLOOP tables are folding and allow you to quickly transform a workspace into an open space to play or rest.

Las mesas MINIFLOOP son abatibles y permiten transformar rápidamente un espacio de trabajo en uno diáfano para jugar o descansar.



*Montessori-inspired
classroom.*





A modular classroom in which cooperative work is the core and the child the protagonist of their experience and learning. With tables that allow various configurations to expand the multiple intelligences.

Un aula modular en la que el trabajo cooperativo es el eje y el niño el protagonista de su experiencia y aprendizaje. Con mesas que permiten diversas configuraciones donde expandir las múltiples inteligencias.

 40 m²  25



MIA MINILIFT

The MIA MINILIFT chair for adults adapts to the height of children's tables for greater comfort for teachers and students.

La silla MIA MINILIFT para adulto se adapta a la altura de las mesas infantiles para un mayor confort de docentes y alumnos.



MIA MINILIFT

The YANG table allows you to quickly create round tables and also different configurations.

La mesa YANG permite crear mesas redondas y diferentes encajes ágilmente.

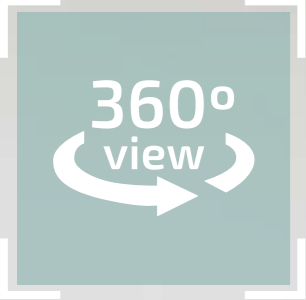

*The importance
of order.*





Storage in the classroom favors both spatial and mental order. Tables and cabinets that, with their design, colour and resistance to shocks and water, favor visual and experiential harmony in the classroom.

El almacenaje en el aula para disponer el material favorece el orden del espacio y el mental. Mesas y armarios que, con su diseño, cromatismo y resistencia a los golpes y al agua, favorecen la armonía visual y experiencial en el aula.

 60 m²  25



GRACE

The GRACE cabinet with trays in two sizes, guided by rails to prevent them from coming out of the cabinet.

El armario GRACE con bandejas de dos tamaños, sujetas por railes para evitar que se salgan del mueble.

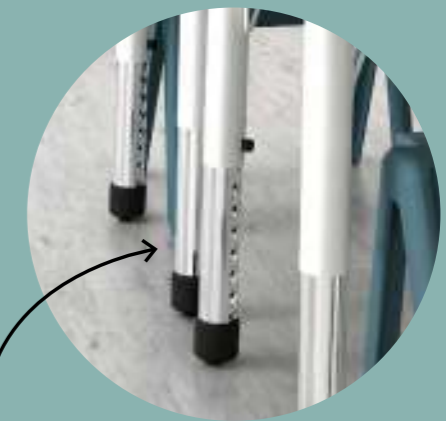

RONY

The RONY table has adjustable legs at different heights for the comfort of all.





La mesa RONY tiene las patas ajustables a diferentes alturas para comodidad de todos.



Furnishing spaces that furnish minds

This is our passion. We understand how students learn and how educators in the 21st century want to teach. As education keeps evolving, so do we.

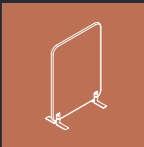
Esta es nuestra pasión. Entendemos cómo aprenden los estudiantes y cómo quieren enseñar los docentes del siglo XXI. A medida que la educación continúe evolucionando, nosotros también.

CHAIRS SILLAS 92	
SOFT SEATING SOFT SEATING 110	
TABLES MESAS 118	
ACOUSTIC ACÚSTICA 148	
CABINETS ARMARIOS 156	
COMPLEMENTS COMPLEMENTOS 178	

Chairs

Reconcile with the movement.
Chairs that facilitate grouping and ungrouping
quickly and without noise, that promote
order and prioritize dynamic comfort.
Chairs not only designed for sitting down.

Reconciliarse con el movimiento. Sillas
que facilitan el agruparse y desagruparse
ágilmente y sin ruidos, que favorecen el orden
y priorizan un confort dinámico. Sillas no solo
pensadas para el momento de sentarse.





MIA



MIA BASIC



MIA CANTILEVER



MIA CASTORS



MIA MINI LIFT



MIA LIFT



MIA BIG LIFT



MIA STOOL



MIA STORE



MIA TABLE





MIA BASIC

Ref. 1028



MIA CANTILEVER

Ref. 1027



SIZE

(+info P. 191)

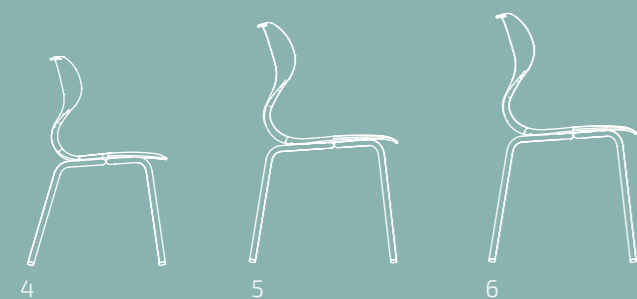

OPTIONS



SIZE

(+info P. 191)



OPTIONS





MIA CASTORS

Ref. 1029



MIA MINI LIFT

Ref. 169



SIZE (+info P. 191)

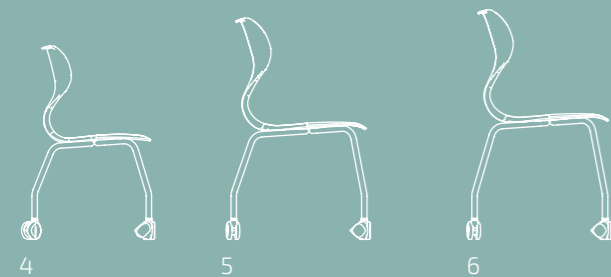

OPTIONS



SIZE (+info P. 191)



DETAILS





MIA LIFT

Ref. 1035



MIA BIG LIFT

Ref. 1039



SIZE (+info P. 191)

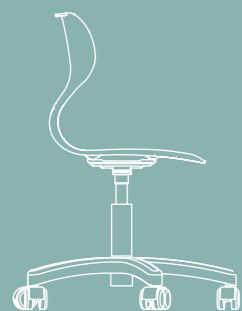

40-51 CM

OPTIONS



DETAILS



SIZE (+info P. 191)



40-51 CM

OPTIONS

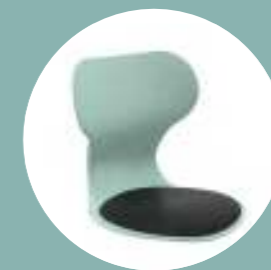



MIA STOOL

Ref. 1030



MIA STORE

Ref. 1038



SIZE (+info P. 191)

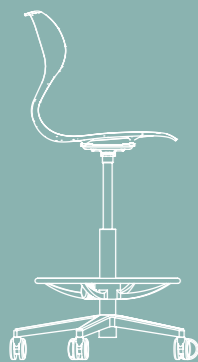

58-83 CM

OPTIONS



DETAILS



SIZE (+info P. 191)



7

OPTIONS



DETAILS





MIA TABLE

Ref. 1036



360°



SIZE
(+info P. 191)

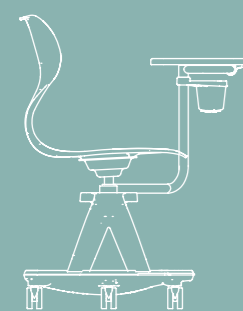

57X33 CM

OPTIONS



DETAILS



How does it work? Watch the video here:
¿Cómo funciona? Mira el vídeo aquí:





ZTOOL

Ref. 1020



ZTOOL TROLLEY

Ref. 1037



X 40 ZTOOL



YouTube



How does it work? Watch the video here:
¿Cómo funciona? Mira el vídeo aquí:



SIZE
(+info P. 191)

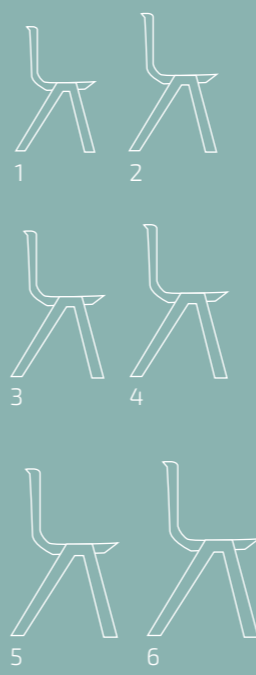

LUCA
Ref. 167



SIZE
(+info P. 191)

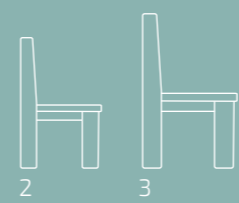

ZOE
Ref. 1044



DETAILS | DETALLES



Soft seating

Socializar, compartir y relajarse.
El mobiliario soft seating permite
crear un espacio para conversaciones
improvisadas y permite dar vida
a zonas del centro educativo
hasta ahora desaprovechadas.

Socialize, share and relax.
Soft seating furniture allows you
to create a space for impromptu
conversations and allows you to bring
life to areas of the educational centre
that have not been used until now.





CHLOE

Ref. CHLOE



CHARLOTTE

Ref. 1041



SIZE

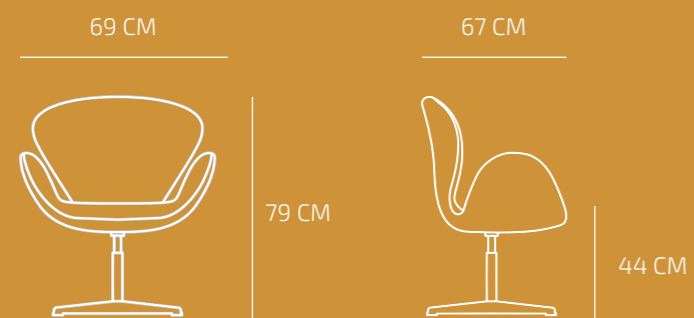

DETAILS



SIZE

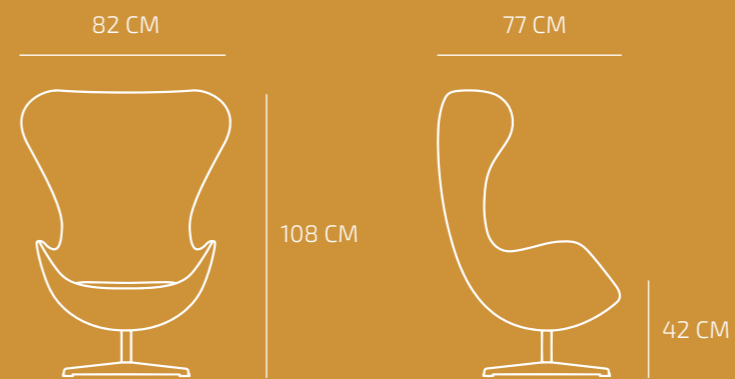

DETAILS

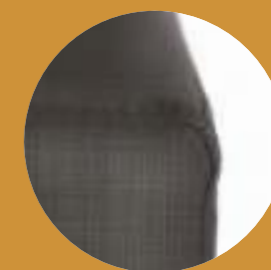



ANGLE

Ref. 12001

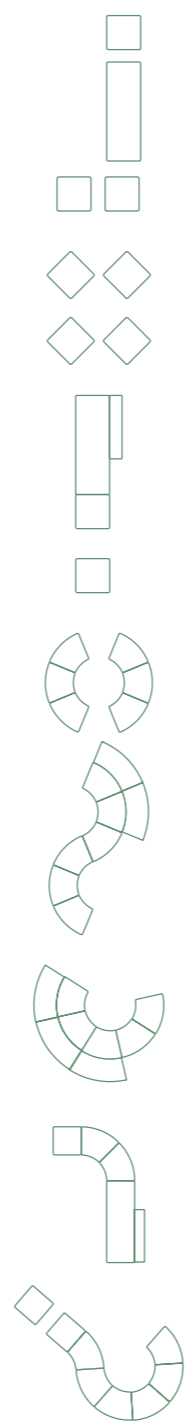

CUBE

Ref. 12002

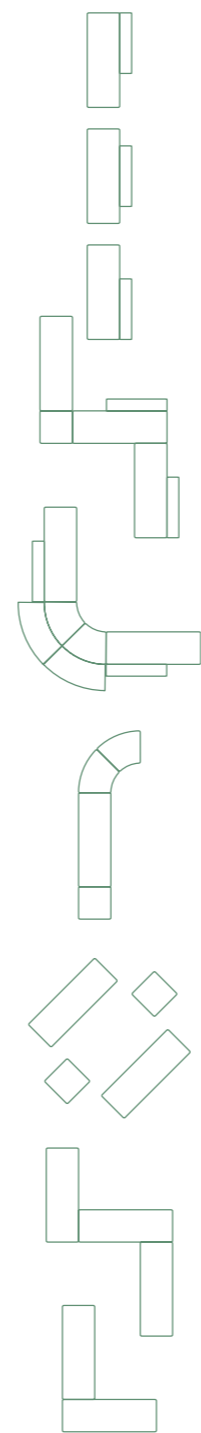

TUBE

Ref. 12003



COMPLETE SOFA

Ref. 12005



SIZE

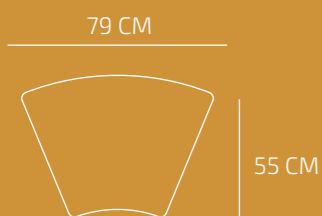

SIZE

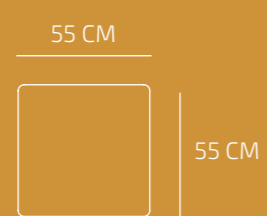

DETAILS



SIZE



SIZE

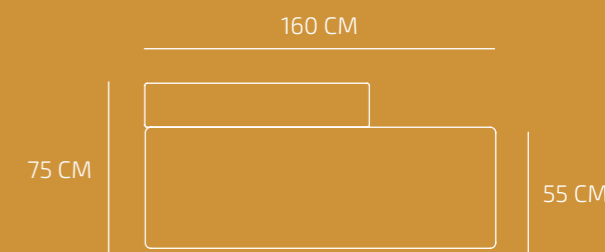



MOVE

Ref. 1608



MINI MOVE

Ref. 1609



SIZE

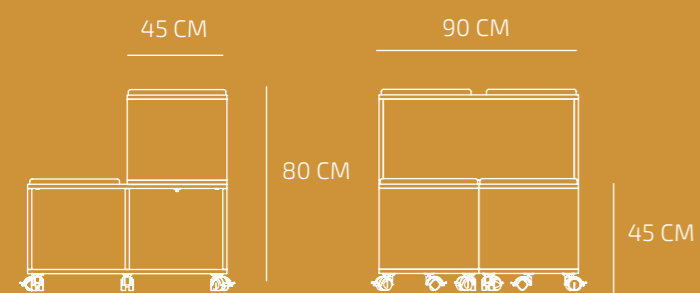

DETAILS



SIZE

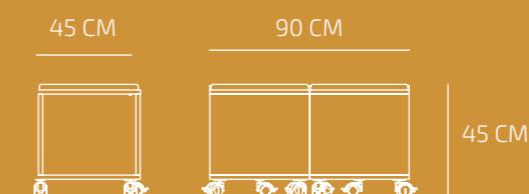

DETAILS



Tables

Work platforms. Tables that allow classrooms to be quickly configured and adapted for collaborative work. With height-adjustable, mobile, easy to fit and storable designs to quickly facilitate the execution of any task.

Plataformas de trabajo. Mesas que permiten configurar y adaptar las aulas ágilmente para el trabajo colaborativo. Con diseños ajustables en altura, móviles, encajables y almacenables para facilitar rápidamente la ejecución de cualquier tarea.





MOON

Ref. 2362



MAX.
H 102 cm



MIN.
H 73 cm



SIZE (+info P. 191)

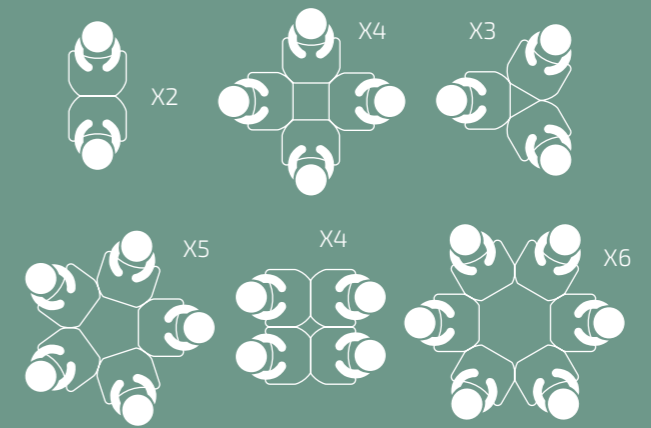
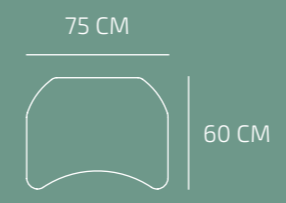

DETAILS





SQUARE

Ref. 2341IN



ARROW

Ref. 2329IN



SIZE (+info P. 191)

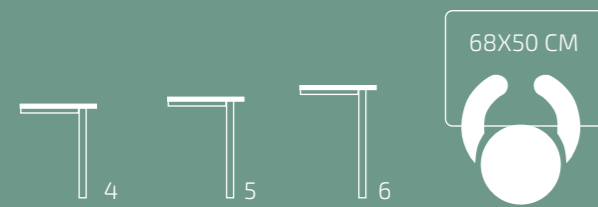

DISTRIBUTION

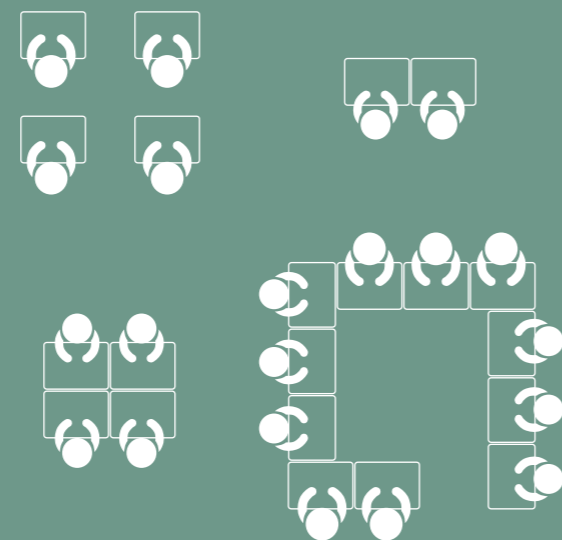

COMBINATIONS



SIZE (+info P. 191)

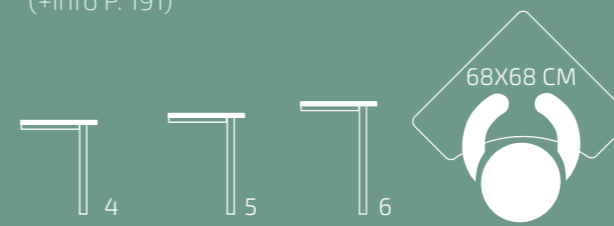

DISTRIBUTION

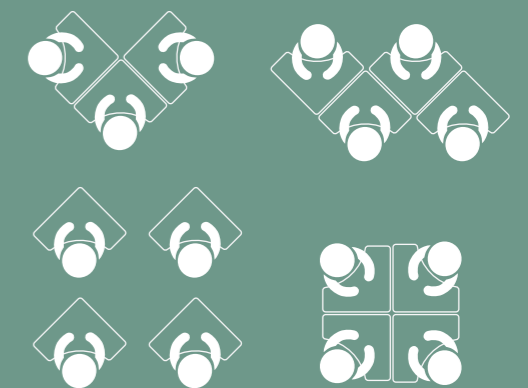

COMBINATIONS





HEXA

Ref. 2336IN



OCTA

Ref. 2335IN



SIZE (+info P. 191)



DISTRIBUTION



COMBINATIONS



SIZE (+info P. 191)



DISTRIBUTION

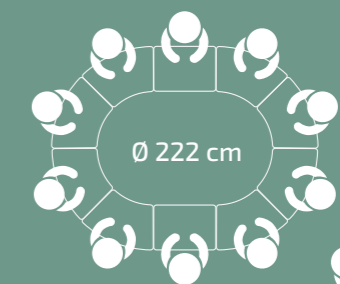

COMBINATIONS





YANG

Ref. 2345RC (1-3)
Ref. 2345R (4-6)



1-3



4-6



WAVE

Ref. 2344RC (1-3)
Ref. 2344R (4-6)



1-3



4-6



SIZE (+info P. 191)



DISTRIBUTION

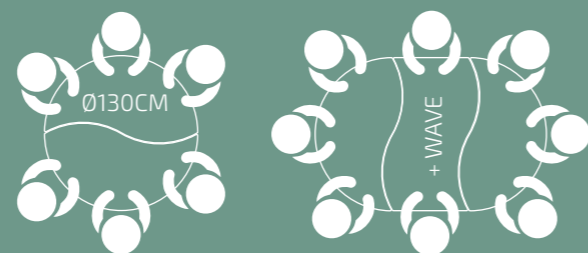

SIZE (+info P. 191)



DISTRIBUTION

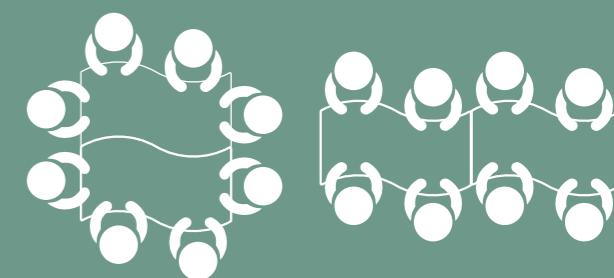



TRISIX

Ref. 2346RCIN (1-3)
Ref. 2346IN (4-6)



1-3



4-6



SIZE

(+info P. 191)



DISTRIBUTION

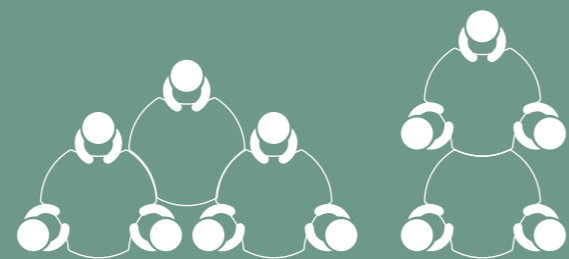



RECTANGLE

Ref. 2352-3 (1-3)
Ref. 2352-6 (4-6)



1-3



4-6



SIZE

(+info P. 191)

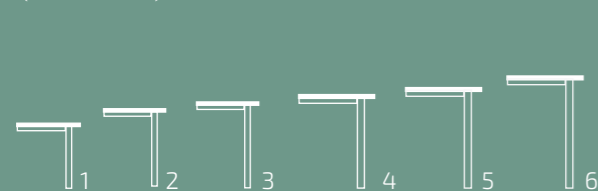

SIZE

(+info P. 189)

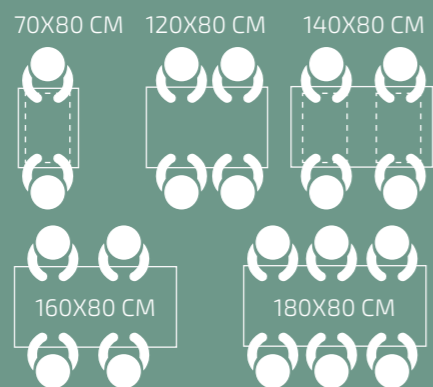

OPTIONS



RECTANGLE PLUS

Ref. 2353-8



SIZE

(+info P. 191)





RECTANGLE TEACHER

Ref. 2355D



SIZE
(+info P. 191)



120X65 CM





NAXEL

Ref. 620



SIZE
(+info P. 191)





SPACE DESIGN

Ref. 261



SIZE
(+info P. 191)

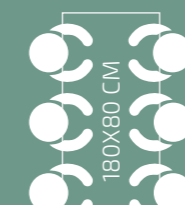
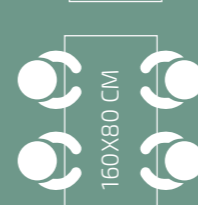
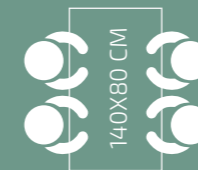

DETAILS



OPTIONS





SPACE PLUS

Ref. 260



SIZE
(+info P. 191)



DETAILS





ALUFLOOP

Ref. 2048R

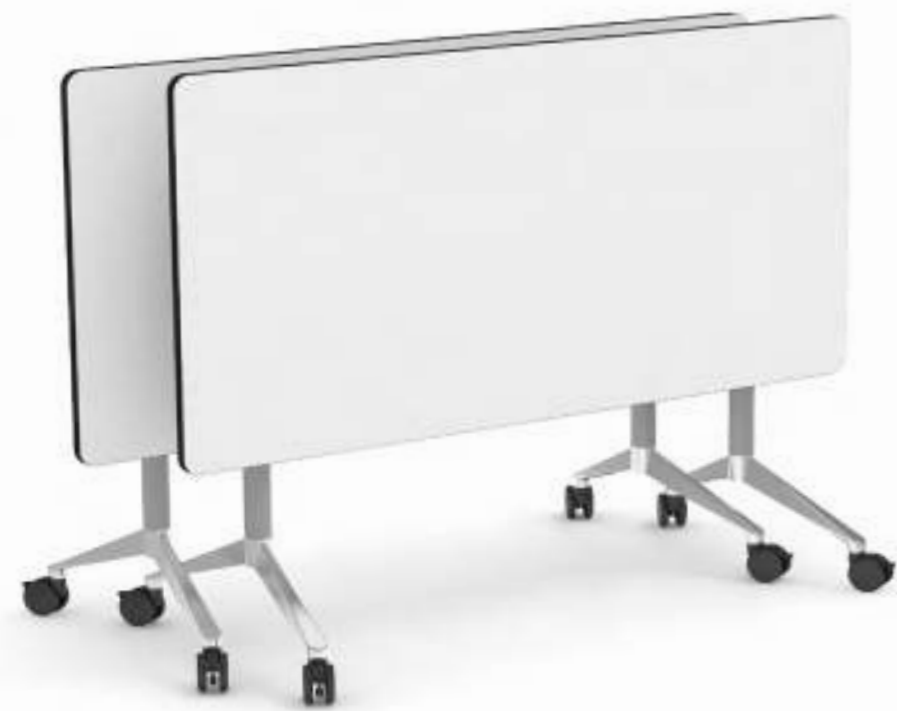
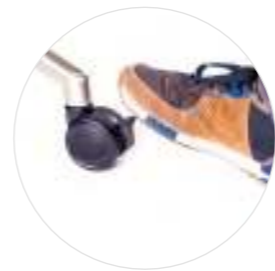

MINIFLOOP

Ref. 2261DNR



SIZE
(+info P. 191)

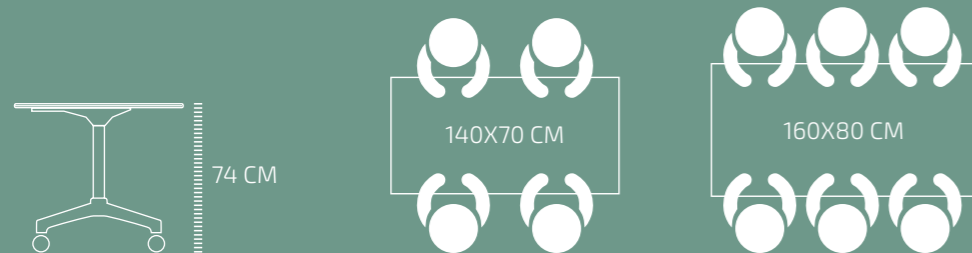

SIZE
(+info P. 191)

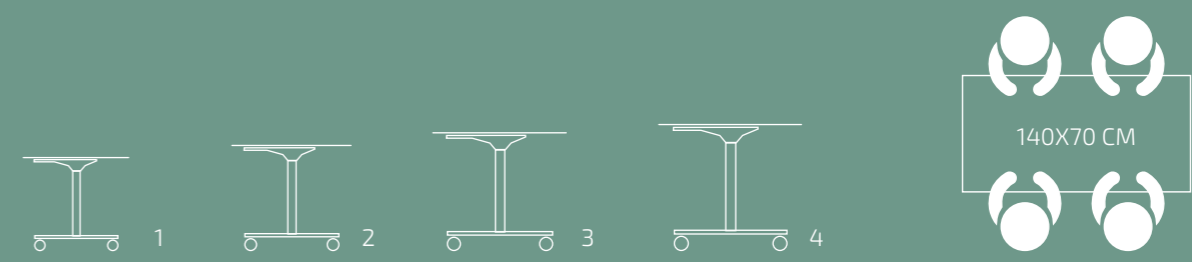



LOUISE

Ref. 2354



H 47 CM

H 70 CM

SIZE

(+info P. 191)

66 CM

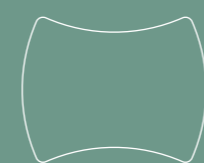

52 CM



DETAILS





RONY

Ref. 2221 - 2220



Injected PP edge



SIZE (+info P. 191)



OPTIONS

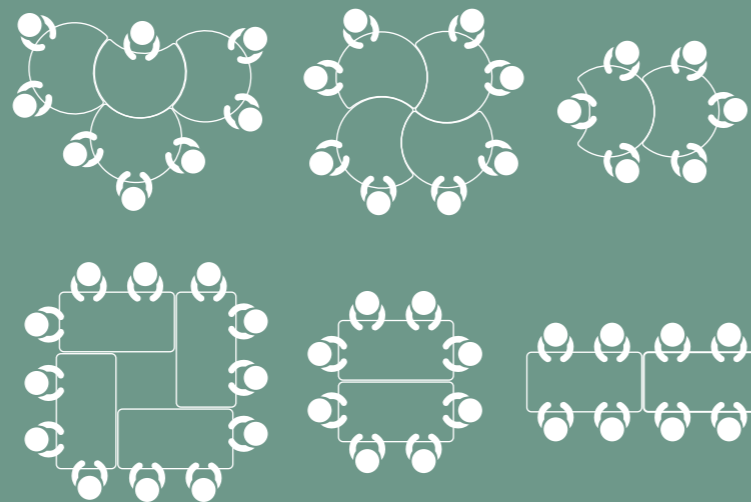



TEO

Ref. 2368



SIZE
(+info P. 191)

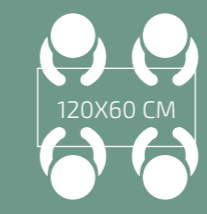

DETAILS



Acoustic



Making the classroom experience better. Acoustic panels and dividers absorb sound, reduce reverberation and improve intelligibility, well-being, concentration and speech performance in classrooms.

Mejorar la experiencia en el aula. Los paneles y separadores acústicos absorben el sonido, reducen la reverberación y mejoran la inteligibilidad, el bienestar, la concentración y el rendimiento del habla en las aulas.



MILETO

Ref. 2102



SIZE

90 X 90 CM



60 X 60 CM



DETAILS | DETALLES

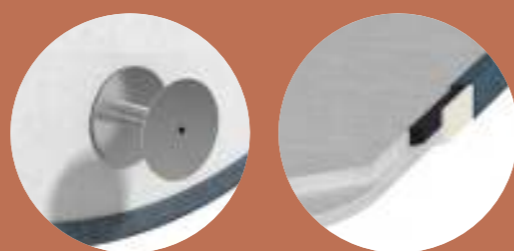

RENE

Ref. 2101

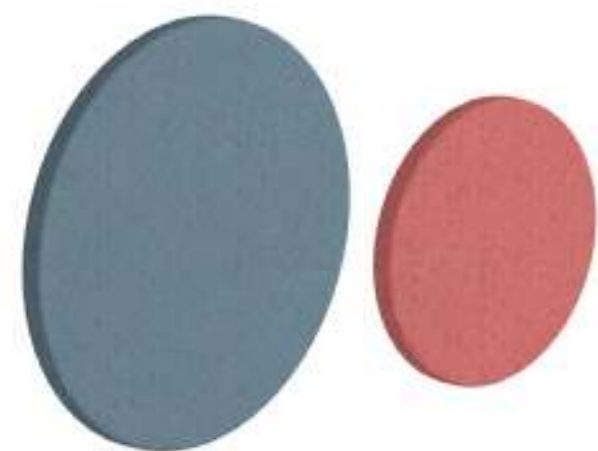

SIZE

Ø 90 CM

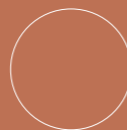

Ø 60 CM



DETAILS | DETALLES

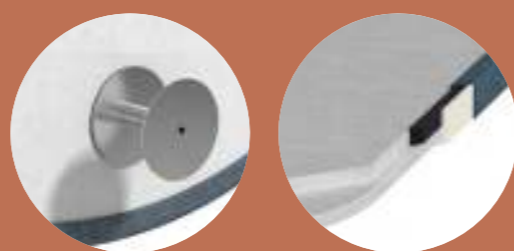

SIZE

120 X 48 CM



SIZE

90 CM

37 CM

125 CM

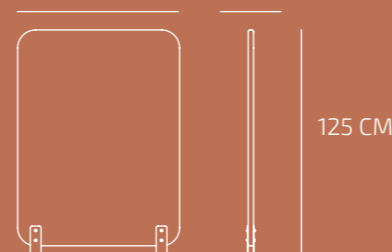

SIZE

120 CM

40 CM

130 CM

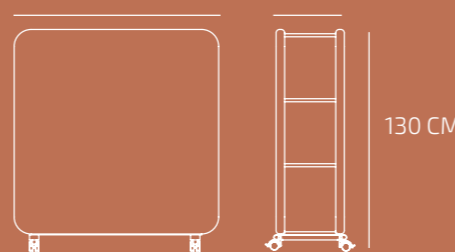

PAUL

Ref. 2103

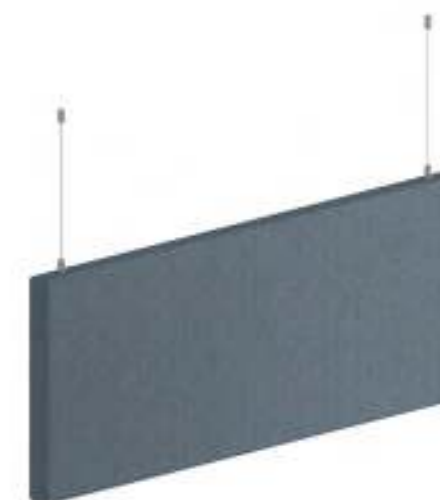

SAMOS

Ref. 2104



ELEA

Ref. 2105





ARA

Ref. 2106-625



SIZE

62,5 X 62,5 CM

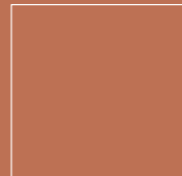

DETAILS



SIZE

62,5 X 120 CM

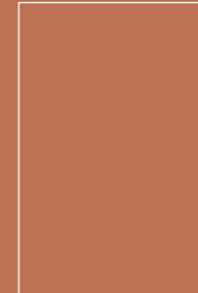

OPTIONS



CERES

Ref. 2106-1200

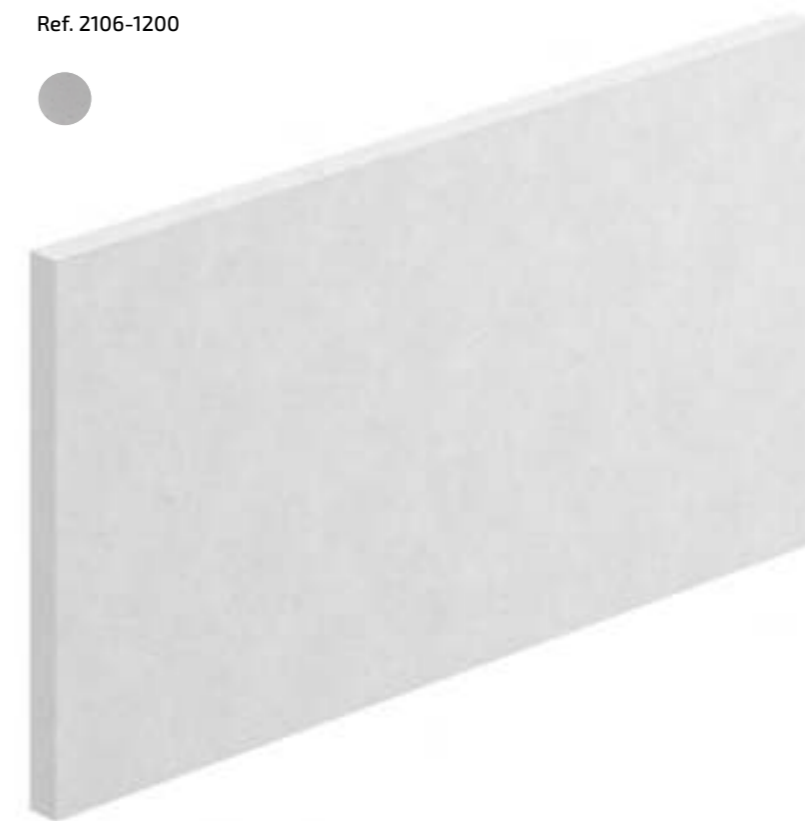

LEDA

Ref. 2106-625



SIZE

62,5 X 62,5 CM

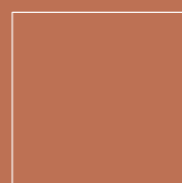

DETAILS



SIZE

62,5 X 120 CM

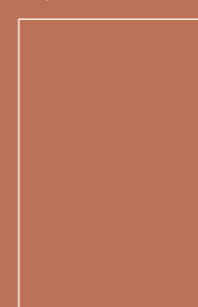

OPTIONS



MENSA

Ref. 2106-1200



ERIS

Frame



Interior panel



Wall panel exterior



INSIDE FURNITURE INCLUDED



SIZE

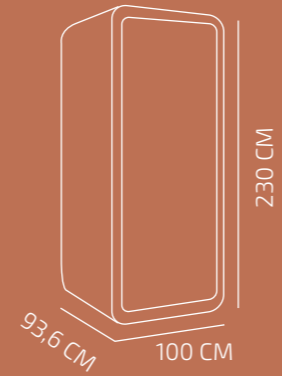

AURE

Frame



Interior panel



Wall panel exterior



INSIDE FURNITURE INCLUDED



SIZE

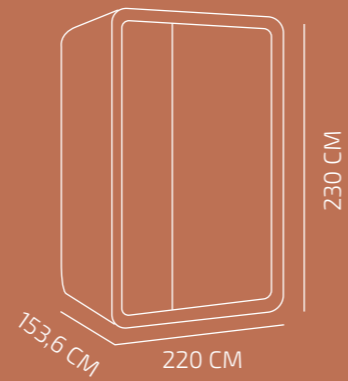

JANO

Frame



Interior panel



Wall panel exterior



INSIDE FURNITURE INCLUDED



SIZE

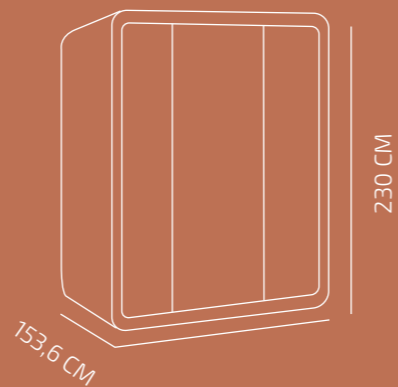

Cabinets

Everything in its place.

Each educational space and classroom have their specific requirements for learning material and distribution. Cabinets are a key element designed to facilitate the different dynamics and the order that each classroom needs.

Todo en su sitio.

Cada espacio educativo y cada aula tiene sus requerimientos específicos de material de aprendizaje y distribución. Los armarios son un elemento clave diseñado para facilitar las diferentes dinámicas y el orden que cada aula necesita.





H 80cm



MARIE
Ref. 732-601



HEDY
Ref. 532-501



ADA
Ref. 532-502



JANE
Ref. 632-504



MERIT
Ref. 632-507



GRACE
Ref. 632-501

H 120cm



IRENE
Ref. 533-501



EMMY
Ref. 533-502



ANNIE
Ref. 633-507



SOPHIE
Ref. 633-501

H 160cm



MILEVA
Ref. 534-501



FLORA
Ref. 534-508



INGE
Ref. 534-509



ELSA
Ref. 634-508



ALICE
Ref. 634-510

H 200cm



EMILIE
Ref. 535-501



MAUD
Ref. 535-508



ROSIE
Ref. 535-521



DAN
Ref. 551

COLOURS



DETAILS



OPTIONS





MARIE

Ref. 732-601

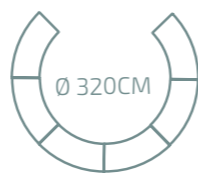

HEDY

Ref. 532-501



ADA

Ref. 532-501



SIZE

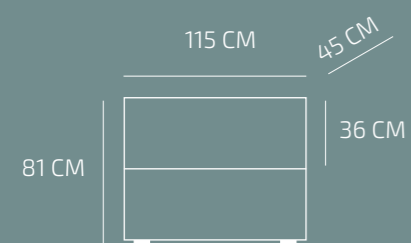

OPTIONS



COMBINATIONS



SIZE

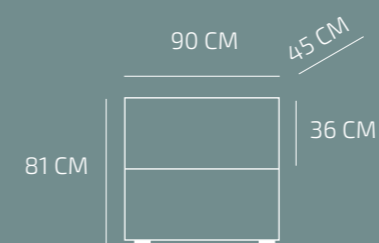

OPTIONS





JANE

Ref. 632-504



MERIT

Ref. 632-507



 x 9



SIZE

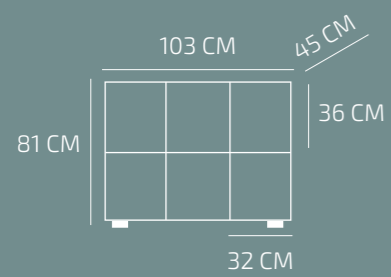

OPTIONS



SIZE

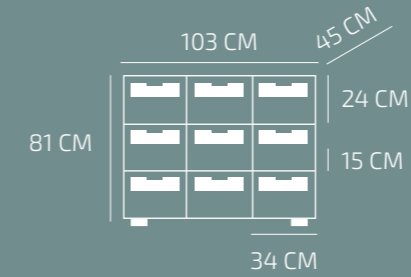

OPTIONS





GRACE

Ref. 632-501



■ x 21



7 cm



■ x 12



15 cm



SIZE

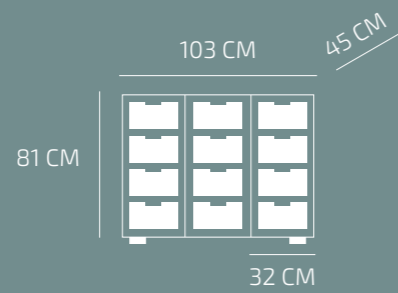
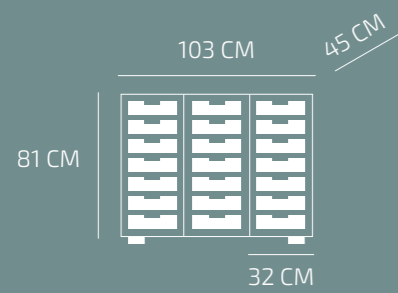

OPTIONS





IRENE

Ref. 533-501



EMMY

Ref. 533-502



SIZE

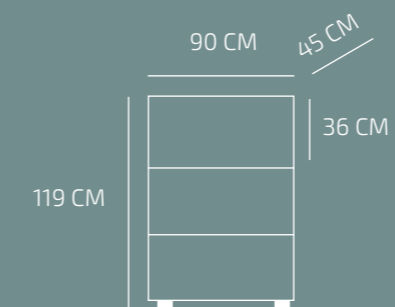

OPTIONS





ANNIE

Ref. 633-507



x15



SOPHIE

Ref. 533-502



x33



x18



SIZE

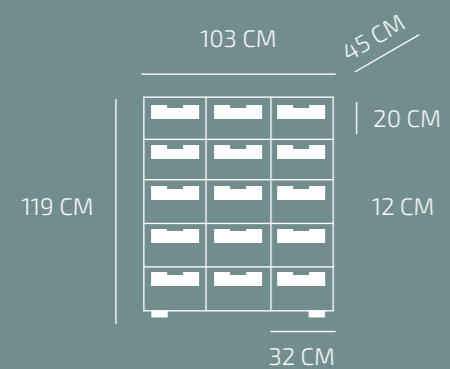

SIZE

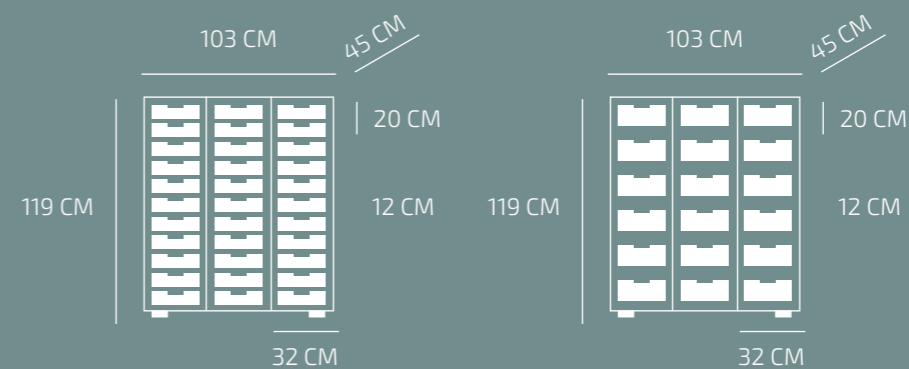



MILEVA

Ref. 534-501



FLORA

Ref. 534-508



INGE

Ref. 534-509



SIZE

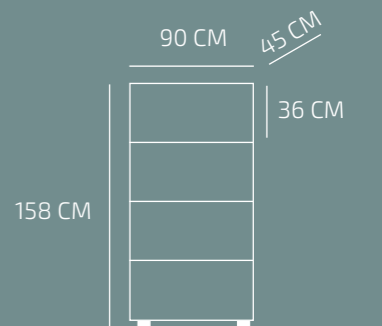

OPTIONS





ELSA

Ref. 634-508



ALICE

Ref. 634-510



x 21



x 12



SIZE

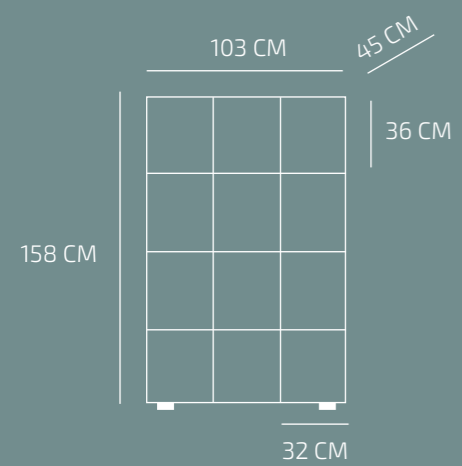

SIZE

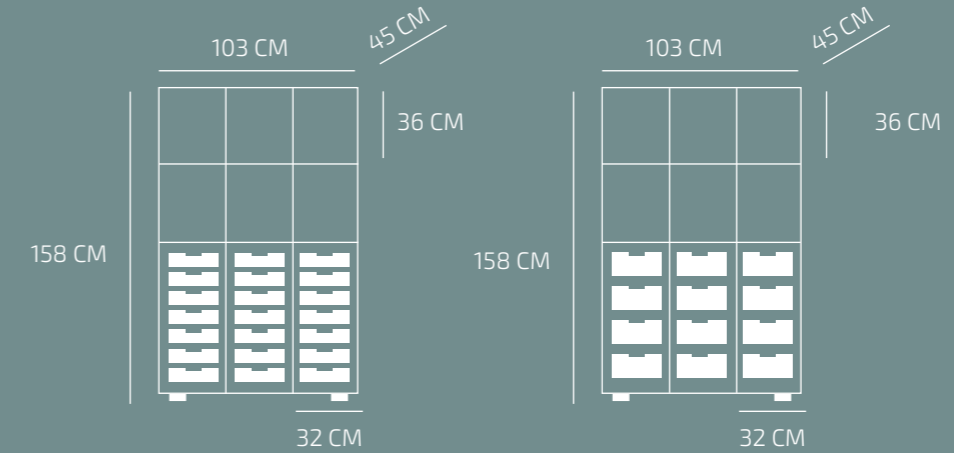



EMILIE

Ref. 535-501



MAUD

Ref. 535-508



ROSIE

Ref. 535-521



SIZE

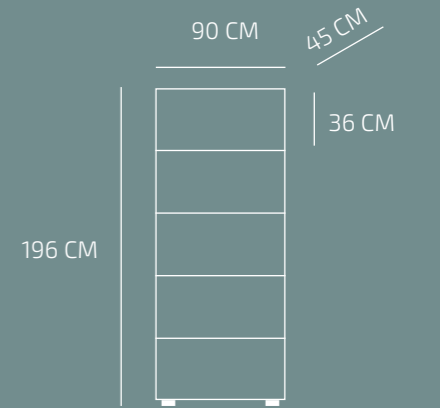

OPTIONS

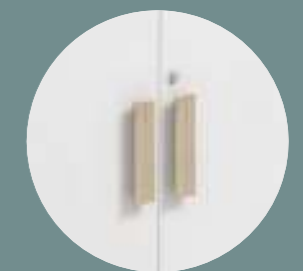



DAN

Ref. 551



SIZE

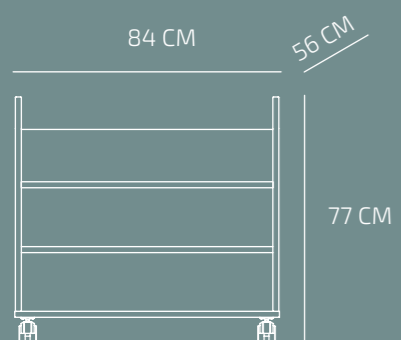

Complements

For a smoother experience.
Support tools designed to facilitate
collaborative learning dynamics and a fluid
and orderly cohabitation in the classroom.

Para una experiencia más fluida.
Herramientas de apoyo pensadas para facilitar
las dinámicas de aprendizaje colaborativo y
una fluida y ordenada convivencia en el aula.





SIZE

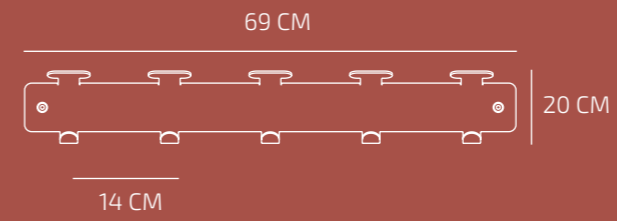

MARCUS

Ref. 7028



SIZE

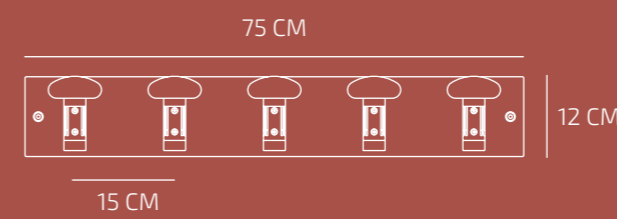

PEGGY

Ref. 751





LILY
Ref.4001



SIZE

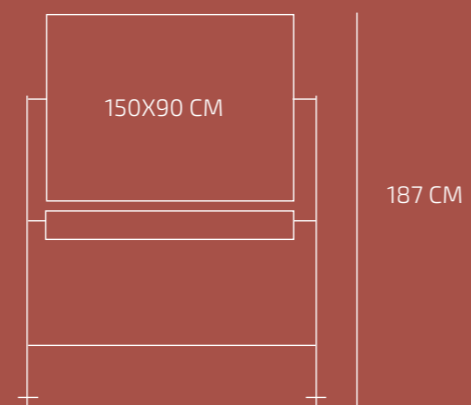

DETAILS



MINI LILY
Ref. 4002



Ref. 7029



SIZE

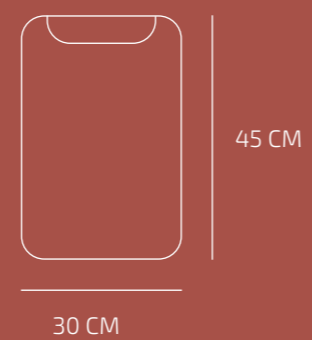

Classroom design service

mirplayschool.com

The team in Mirplay School helps you adapt your centre's learning spaces to the new educational dynamics taking place in it. Creating and optimising different spaces in a classroom, improving its acoustics and facilitating the orderly movement of students can be very easy.

With versatile furniture that is easy to move and store, comfortable and capable of coping with daily use, a wide range of possibilities opens up.

El equipo de Mirplay School te ayuda a adaptar los espacios de aprendizaje de tu centro a las nuevas dinámicas educativas que en él se suceden. Crear y optimizar diferentes espacios en un aula, mejorar su acústica y facilitar el movimiento ordenado de los alumnos puede ser muy sencillo.

Con mobiliario versátil, fácilmente desplazable y almacenable, de diseño cómodo y que absorba su uso diario, se abre un gran abanico de posibilidades.



FLOOR LAYOUT DISTRIBUCIÓN EN PLANTA

We offer a proposal for the distribution of your space in a plan view, simple and easy to implement.

Te planteamos una propuesta de distribución de tu espacio en una vista en planta, sencilla y fácil de poner en práctica.



3D VIEWS OF YOUR SPACE VISTAS EN 3D DE TU ESPACIO

Do you want to visualize how it will look like? You just have to tell us what the space is like, what you want to achieve and we will make you a proposal in 3D image.

¿Quieres visualizar cómo quedará? Solo tienes que indicarnos cómo es el espacio, qué quieres conseguir y nosotros te hacemos una propuesta en imagen 3D.



ARCHITECTURAL DRAFT ANTEPROYECTO ARQUITECTÓNICO

Our team of architects projects and adapts the space so that it supports and stimulates the activities that will take place in it.

Nuestro equipo de arquitectos proyecta y adapta el espacio para que sostenga y dinamice las actividades que en él tendrán lugar.



FURNISHING PROJECT PROYECTO DE DECORACIÓN

We guide you in interior design decisions to create a comprehensive decoration proposal.

Te acompañamos y guiamos en las decisiones de interiorismo para crear una propuesta integral de decoración.

MIA BASIC
1028



p. 96

MIA CANTILEVER
1027



p. 97

MIA CASTORS
1029



p. 98

MIA MINI LIFT
169



p. 99

MIA LIFT
1035



p. 100

OCTA
2335IN



p. 125

YANG
2345R



p. 126

WAVE
2344R



p. 127

TRISIX
2346IN



p. 128

RECTANGLE
2352



p. 130

MIA BIG LIFT
1039



p. 101

MIA STOOL
1030



p. 102

MIA STORE
1038



p. 103

MIA TABLE
1036



p. 104

ZTOOL
1020



p. 106

RECTANGLE PLUS
2353



p. 131

RECTANGLE TEACHER
2355D



p. 133

NAXEL
620



p. 134

SPACE DESIGN
261



p. 137

SPACE PLUS
260



p. 138

ZTOOL TROLLEY
1037



p. 106

LUCA
167-1/2/3/4/5/6



p. 109

ZOE
1044



p. 109

CHLOE



p. 112

CHARLOTTE
1041



p. 113

ALUFLOOP
2048R



p. 140

MINIFLOOP
226DNR



p. 141

LOUISE
2354



p. 143

RONY
2221



p. 144

RONY
2220



p. 144

ANGLE
12001



p. 114

CUBE
12002



p. 114

TUBE
12003



p. 115

COMPLETE SOFA
12005



p. 115

MOVE
1608



p. 116

TEO
2368



p. 147

MILETO
2102



p. 150

RENE
2101



p. 150

PAUL
2103



p. 151

SAMOS
2104



p. 151

MINI MOVE
1609



p. 117

MOON
2362



p. 121

SQUARE
2341IN



p. 122

ARROW
2329IN



p. 123

HEXA
2336IN



p. 124

ELEA
2105



p. 151

ARA
2106-625

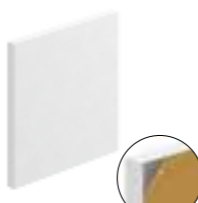

p. 152

LEDA
2106-625



p. 152

CERES
2106-1200



p. 153

MENSA
2106-1200



p. 153

ERIS



p. 154

AURE



p. 154

JANO



p. 154

MARIE
732-601



p. 160

HEDY
532-501



p. 160

MINI LILY
4002



p. 182

ADA
532-502



p. 160

JANE
632-504



p. 162

MERIT
632-507



p. 163

GRACE
632-501



p. 164

IRENE
533-501



p. 167

MINI LILY HOOK
7029



p. 182

EMMY
533-502



p. 167

ANNIE
633-507



p. 168

SOPHIE
633-501



p. 169

MILEVA
534-501



p. 170

FLORA
534-508



p. 170

INGE
534-509



p. 171

ELSA
634-508



p. 172

ALICE
634-510



p. 173

EMILIE
535-501



p. 174

MAUD
535-508



p. 174

ROSIE
535-521



p. 175

DAN
551



p. 176

MARCUS
7028



p. 181

PEGGY
751



p. 181

LILY
4001



p. 182



Our products are designed and manufactured according to the corresponding implementation regulations:

Chairs and tables for educational institutions.
 UNE EN 1729-1: 07 / UNE EN 1729-2: 07.
 Dimensions, safety requirements and test methods.
 According to UNE 56843:01 furniture specifications.
 UNE-EN 71-3:94 - Migration of metallic elements.

Mirplay certifies its products in European laboratories SGS.

Nuestros productos están diseñados y fabricados según las normativas de aplicación correspondientes. Relación de normas aplicables:

Sillas y mesas para centros educativos.
 UNE EN 1729-1: 07 / UNE EN 1729-2: 07.
 Dimensiones, requisitos de seguridad y métodos de ensayo.
 Según especificaciones UNE 56.843: 01 mobiliario.
 UNE - EN 71-3: 94 - Migración elementos metálicos.

Mirplay certifica sus productos en el laboratorio de referencia internacional SGS.

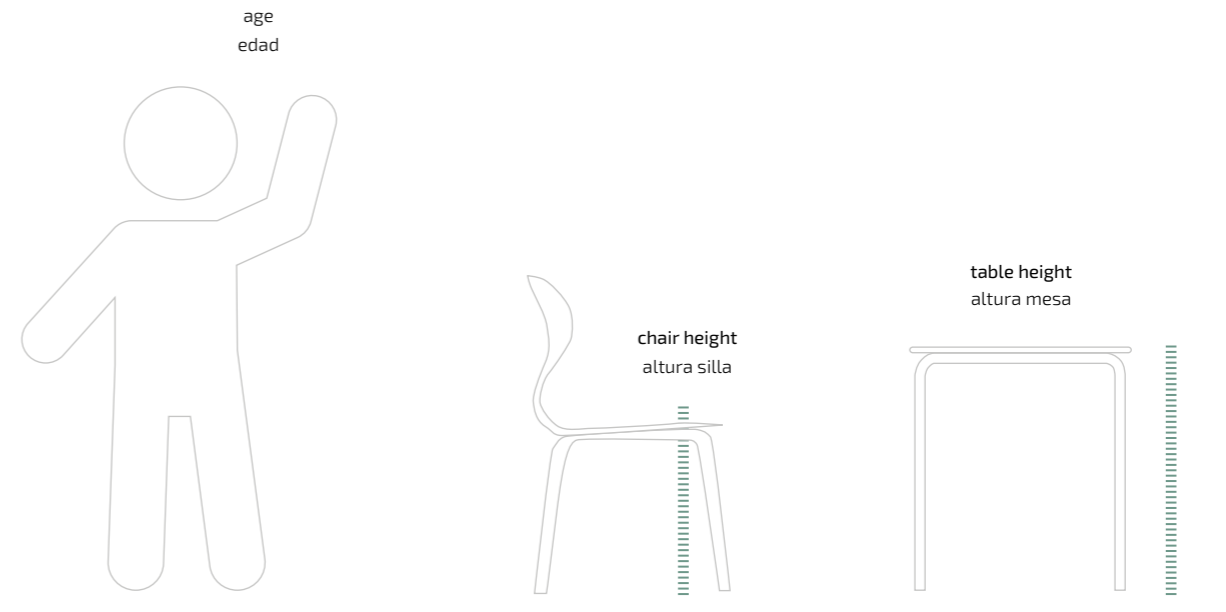

SIZE TALLA	AGE EDAD	CHAIR HEIGHT ALTURA ASIENTO	TABLE HEIGHT ALTURA MESA
0	1-2	21 cm	40 cm
1	2-3	26 cm	46 cm
2	3-4	30 cm	52 cm
3	4-6	34 cm	59 cm
4	6-8	38 cm	65 cm
5	8-10	42 cm	70 cm
6	+12	46 cm	77 cm
8*	+8	80 cm	100 cm

Size according to European regulation UNE EN 1729-1: 07 / UNE EN 1729-2: 07.
 Tallas según la normativa europea UNE EN 1729-1: 07 / UNE EN 1729-2: 07.



The catalogue's images have not a contractual value. They are illustrative and they cannot correspond exactly with the product. The images shown in this catalogue are property of Mobles Mir i Equipaments, its reproduction, distribution, public communication and transformation are forbidden without authorization.

Las imágenes de este catálogo no tienen un valor contractual. Son ilustrativas y podrían no corresponder exactamente al producto. Las imágenes que aparecen en este catálogo son propiedad de Mobles Mir i Equipaments, queda prohibida su reproducción, distribución, comunicación pública y transformación, sin autorización.

*Equivalence UNE-EN 1729-1 size 5 dimensions for tables to work standing up.

*Equivalencia UNE-EN 1729-1 a dimensiones talla 5 para mesas de trabajo de pie.

Mirplay[®]

school



mirplayschool.com

HEADQUARTERS

BP-4313 - Punt Km 28,7
08279 Avinyó · BCN · SPAIN

+34 938 124 452
info@mirplayschool.com

MIRPLAY MÉXICO
mexico@mirplay.com

MIRPLAY UK
uk@mirplay.com

MIRPLAY ASIA
asia@mirplay.com